

FOLTON TABLE

FOL-T

TEARSHEET

STUDIO LUDDITE

©2024 STUDIO LUDDITE

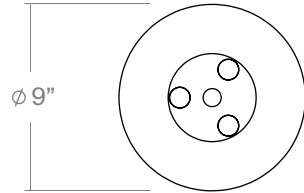

(TOP)

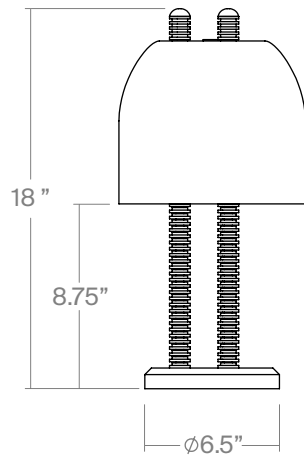

(FRONT)

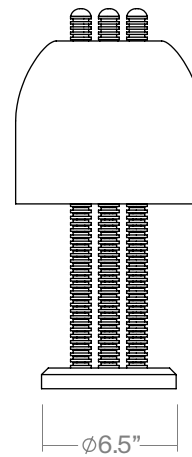

(SIDE)

Featuring stacked leather hide disks as the focal detail, the Folton fixture celebrates the imperfection of natural materials. The frosted glass shade allows light to illuminate the leather's edge, while the supports visually extend through the fixture to create a continuous union of components.

STUDIO LUDDITE

2350 BROADWAY STUDIO 101
NEW YORK, NY 10024

917 423 2443
SALES@STUDIOLUDDITE.COM

DIMENSIONS	HEIGHT 18.75" WIDTH 9" DEPTH 9" WEIGHT 8 LBS
TYPE	TABLE LAMP
LAMPIGN	(X2) E12 BULB
CERTIFICATIONS	UL CERTIFIED



FOLTON CEILING IN

BLACKENED BRASS
NATURAL LEATHER

STUDIO LUDDITE

2350 BROADWAY STUDIO 101
NEW YORK, NY 10024

917 423 2443
SALES@STUDIOLUDDITE.COM

LEATHER FINISHES

BLACK
BROWN
NATURAL

METAL FINISHES

AGED BRASS
AGED SILVER
BLACKENED BRASS